



### Looser Gleitlager LG 41

Zylinderbüchsen	10.2
Flanschbüchsen	10.6

### Technische Daten

Toleranzen und Einbauempfehlungen	10.8
Masse der Schmiernute	10.10
Wellenwerkstoffe	10.10
Werkstoffdaten	10.11

### Looser bearing LG 41

Cylindrical bearing	10.2
Flanged bearing	10.6

### Technical data

Tolerances and installation recommendations	10.8
Dimensions of the lubrication groove	10.10
Shaft materials	10.10
Material data	10.11

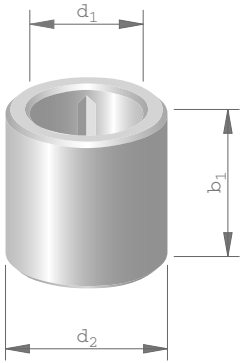

#### Schmiernuten

Bis zu einem Innendurchmesser von 12 mm werden die Büchsen ohne Schmiernut, ab 14 mm mit einer axialen Schmiernut geliefert.

#### Lubrication grooves

Up to an inner diameter of 12 mm, the bushings are supplied without a lubrication groove; from 14 mm an axial lubrication groove is provided.

#### Empfohlene Einbautoleranzen:

Aufnahmebohrung: H7  
Welle: e7

Übrige Toleranzen siehe Seiten 8 + 9

#### Wir liefern zudem:

- Sonderanfertigungen nach Zeichnung
- andere Werkstoffe für Spezialanwendungen

#### Permissible installation tolerances:

Location hole: H7  
Shaft: e7

Other tolerances see pages 8 + 9

#### We also supply:

- Custom-made products according to drawing
- Other metals for special applications

Wellen-Ø [mm] Shaft-Ø [mm]	Abmessungen [mm] Dimensions [mm]			Gewicht [g] Weight [g]	Artikelnummer Article number
	d <sub>1</sub>	d <sub>2</sub>	b <sub>1</sub>		
5	5	10	6	3,0	<b>41.1.005.006</b>
	5	10	8	4,0	<b>41.1.005.008</b>
	5	10	10	6,0	<b>41.1.005.010</b>
6	6	12	6	4,0	<b>41.1.006.006</b>
	6	12	8	6,0	<b>41.1.006.008</b>
	6	12	12	8,0	<b>41.1.006.012</b>
7	7	12	8	5,0	<b>41.1.007.008</b>
	7	12	10	6,0	<b>41.1.007.010</b>
	7	12	12	7,0	<b>41.1.007.012</b>
8	8	14	8	6,0	<b>41.1.008.008</b>
	8	14	12	10,0	<b>41.1.008.012</b>
	8	14	16	13,0	<b>41.1.008.016</b>
9	9	14	10	8,0	<b>41.1.009.010</b>
	9	14	16	13,0	<b>41.1.009.016</b>
	9	14	20	16,0	<b>41.1.009.020</b>
10	10	16	10	10,0	<b>41.1.010.010</b>
	10	16	16	16,0	<b>41.1.010.016</b>
	10	16	20	20,0	<b>41.1.010.020</b>
12	12	18	12	13,0	<b>41.1.012.012</b>
	12	18	16	20,0	<b>41.1.012.016</b>
	12	18	25	30,0	<b>41.1.012.025</b>
14	14	20	12	15,0	<b>41.1.014.012</b>
	14	20	20	25,0	<b>41.1.014.020</b>
	14	20	30	40,0	<b>41.1.014.030</b>
15	15	22	16	25,0	<b>41.1.015.016</b>
	15	22	20	35,0	<b>41.1.015.020</b>
	15	22	30	50,0	<b>41.1.015.030</b>
16	16	22	16	23,0	<b>41.1.016.016</b>
	16	22	20	30,0	<b>41.1.016.020</b>
	16	22	30	46,0	<b>41.1.016.030</b>
17	17	25	16	35,0	<b>41.1.017.016</b>
	17	25	20	43,0	<b>41.1.017.020</b>
	17	25	30	65,0	<b>41.1.017.030</b>
18	18	25	16	30,0	<b>41.1.018.016</b>
	18	25	20	40,0	<b>41.1.018.020</b>
	18	25	30	60,0	<b>41.1.018.030</b>
20	20	28	20	50,0	<b>41.1.020.020</b>
	20	28	30	80,0	<b>41.1.020.030</b>
	20	28	40	105,0	<b>41.1.020.040</b>
22	22	32	20	70,0	<b>41.1.022.020</b>
	22	32	30	110,0	<b>41.1.022.030</b>
	22	32	40	148,0	<b>41.1.022.040</b>
25	25	35	25	100,0	<b>41.1.025.025</b>
	25	35	35	140,0	<b>41.1.025.035</b>
	25	35	50	200,0	<b>41.1.025.050</b>

## Looser Gleitlager LG 41 – Zylinderbüchsen

### Looser bearing LG 41 – Cylindrical bearing



Wellen-Ø [mm] Shaft-Ø [mm]	Abmessungen [mm] Dimensions [mm]			Gewicht [g] Weight [g]	Artikelnummer Article number
	d <sub>1</sub>	d <sub>2</sub>	b <sub>1</sub>		
28	28	40	25	140,0	<b>41.1.028.025</b>
	28	40	35	197,0	<b>41.1.028.035</b>
	28	40	50	282,0	<b>41.1.028.050</b>
30	30	40	30	140,0	<b>41.1.030.030</b>
	30	40	45	215,0	<b>41.1.030.045</b>
	30	40	60	290,0	<b>41.1.030.060</b>
35	35	45	35	195,0	<b>41.1.035.035</b>
	35	45	50	275,0	<b>41.1.035.050</b>
	35	45	70	390,0	<b>41.1.035.070</b>
40	40	50	40	245,0	<b>41.1.040.040</b>
	40	50	60	370,0	<b>41.1.040.060</b>
	40	50	80	500,0	<b>41.1.040.080</b>
45	45	55	45	315,0	<b>41.1.045.045</b>
	45	55	60	415,0	<b>41.1.045.060</b>
	45	55	80	550,0	<b>41.1.045.080</b>
50	50	60	50	380,0	<b>41.1.050.050</b>
	50	60	70	530,0	<b>41.1.050.070</b>
	50	60	100	760,0	<b>41.1.050.100</b>
55	55	70	50	640,0	<b>41.1.055.050</b>
	55	70	70	910,0	<b>41.1.055.070</b>
	55	70	100	1280,0	<b>41.1.055.100</b>
60	60	75	60	840,0	<b>41.1.060.060</b>
	60	75	90	1260,0	<b>41.1.060.090</b>
	60	75	120	1680,0	<b>41.1.060.120</b>
65	65	80	60	910,0	<b>41.1.065.060</b>
	65	80	90	1360,0	<b>41.1.065.090</b>
	65	80	120	1810,0	<b>41.1.065.120</b>
70	70	85	60	960,0	<b>41.1.070.060</b>
	70	85	90	1440,0	<b>41.1.070.090</b>
	70	85	120	1930,0	<b>41.1.070.120</b>
75	75	90	70	1190,0	<b>41.1.075.070</b>
	75	90	100	1700,0	<b>41.1.075.100</b>
	75	90	140	2380,0	<b>41.1.075.140</b>
80	80	95	70	1260,0	<b>41.1.080.070</b>
	80	95	100	1800,0	<b>41.1.080.100</b>
	80	95	140	2520,0	<b>41.1.080.140</b>
85	85	100	70	1330,0	<b>41.1.085.070</b>
	85	100	100	1900,0	<b>41.1.085.100</b>
	85	100	140	2660,0	<b>41.1.085.140</b>
90	90	110	80	2220,0	<b>41.1.090.080</b>
	90	110	120	3300,0	<b>41.1.090.120</b>
	90	110	160	4400,0	<b>41.1.090.160</b>
95	95	115	80	2320,0	<b>41.1.095.080</b>
	95	115	120	3400,0	<b>41.1.095.120</b>
	95	115	160	4640,0	<b>41.1.095.160</b>

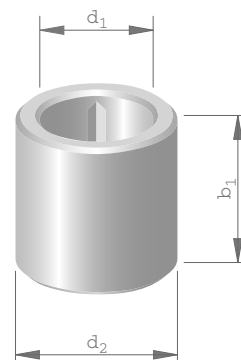

#### Schmiernuten

Bis zu einem Innendurchmesser von 12 mm werden die Büchsen ohne Schmiernut, ab 14 mm mit einer axialen Schmiernut geliefert.

#### Lubrication grooves

Up to an inner diameter of 12 mm, the bushings are supplied without a lubrication groove; from 14 mm an axial lubrication groove is provided.

#### Empfohlene Einbautoleranzen:

Aufnahmebohrung: H7  
Welle: e7

Übrige Toleranzen siehe Seiten 8 + 9

#### Wir liefern zudem:

- Sonderanfertigungen nach Zeichnung
- andere Werkstoffe für Spezialanwendungen

#### Permissible installation tolerances:

Location hole: H7  
Shaft: e7

Other tolerances see pages 8 + 9

#### We also supply:

- Custom-made products according to drawing
- Other metals for special applications

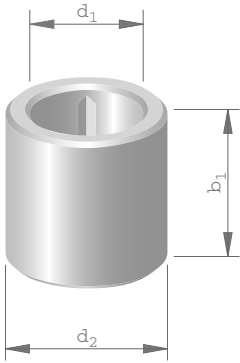

#### Schmiernuten

Bis zu einem Innendurchmesser von 12 mm werden die Büchsen ohne Schmiernut, ab 14 mm mit einer axialen Schmiernut geliefert.

#### Lubrication grooves

Up to an inner diameter of 12 mm, the bushings are supplied without a lubrication groove; from 14 mm an axial lubrication groove is provided.

#### Empfohlene Einbautoleranzen:

Aufnahmebohrung: H7  
Welle: e7

Übrige Toleranzen siehe Seiten 8+9

#### Wir liefern zudem:

- Sonderanfertigungen nach Zeichnung
- andere Werkstoffe für Spezialanwendungen

#### Permissible installation tolerances:

Location hole: H7  
Shaft: e7

Other tolerances see pages 8 + 9

#### We also supply:

- Custom-made products according to drawing
- Other metals for special applications

Wellen-Ø [mm] Shaft-Ø [mm]	Abmessungen [mm] Dimensions [mm]			Gewicht [g] Weight [g]	Artikelnummer Article number
	d <sub>1</sub>	d <sub>2</sub>	b <sub>1</sub>		
100	100	120	80	2400,0	<b>41.1.100.080</b>
	100	120	120	3600,0	<b>41.1.100.120</b>
	100	120	160	4800,0	<b>41.1.100.160</b>
105	105	125	80	2500,0	<b>41.1.105.080</b>
	105	125	120	3750,0	<b>41.1.105.120</b>
	105	125	160	5000,0	<b>41.1.105.160</b>
110	110	130	80	2640,0	<b>41.1.110.080</b>
	110	130	140	4620,0	<b>41.1.110.140</b>
	110	130	200	6600,0	<b>41.1.110.200</b>
120	120	140	80	2880,0	<b>41.1.120.080</b>
	120	140	140	5040,0	<b>41.1.120.140</b>
	120	140	200	7200,0	<b>41.1.120.200</b>
130	130	150	90	3470,0	<b>41.1.130.090</b>
	130	150	140	5400,0	<b>41.1.130.140</b>
	130	150	200	7700,0	<b>41.1.130.200</b>
140	140	160	90	3830,0	<b>41.1.140.090</b>
	140	160	160	6800,0	<b>41.1.140.160</b>
	140	160	200	8500,0	<b>41.1.140.200</b>
150	150	170	100	4400,0	<b>41.1.150.100</b>
	150	170	160	7000,0	<b>41.1.150.160</b>
	150	170	240	10610,0	<b>41.1.150.240</b>
160	160	180	100	4700,0	<b>41.1.160.100</b>
	160	180	160	7500,0	<b>41.1.160.160</b>
	160	180	240	11280,0	<b>41.1.160.240</b>
170	170	190	100	4950,0	<b>41.1.170.100</b>
	170	190	160	7900,0	<b>41.1.170.160</b>
	170	190	240	11940,0	<b>41.1.170.240</b>
180	180	200	100	5300,0	<b>41.1.180.100</b>
	180	200	160	8400,0	<b>41.1.180.160</b>
	180	200	240	12600,0	<b>41.1.180.240</b>
190	190	210	120	6600,0	<b>41.1.190.120</b>
	190	210	200	11060,0	<b>41.1.190.200</b>
	190	210	300	16600,0	<b>41.1.190.300</b>
200	200	220	120	6950,0	<b>41.1.200.120</b>
	200	220	200	11600,0	<b>41.1.200.200</b>
	200	220	300	17420,0	<b>41.1.200.300</b>
210	210	230	120	7300,0	<b>41.1.210.120</b>
	210	230	200	12160,0	<b>41.1.210.200</b>
	210	230	300	18240,0	<b>41.1.210.300</b>
220	220	240	140	8900,0	<b>41.1.220.140</b>
	220	240	250	15900,0	<b>41.1.220.250</b>
	220	240	350	22260,0	<b>41.1.220.350</b>
230	230	250	140	9290,0	<b>41.1.230.140</b>
	230	250	250	16590,0	<b>41.1.230.250</b>
	230	250	350	23220,0	<b>41.1.230.350</b>

## Looser Gleitlager LG 41 – Zylinderbüchsen Looser bearing LG 41 – Cylindrical bearing



Wellen-Ø [mm] Shaft-Ø [mm]	Abmessungen [mm] Dimensions [mm]			Gewicht [g] Weight [g]	Artikelnummer Article number
	d <sub>1</sub>	d <sub>2</sub>	b <sub>1</sub>		
240	240	260	140	9670,0	<b>41.1.240.140</b>
	240	260	250	17280,0	<b>41.1.240.250</b>
	240	260	350	24200,0	<b>41.1.240.350</b>
250	250	270	140	10060,0	<b>41.1.250.140</b>
	250	270	250	17970,0	<b>41.1.250.250</b>
	250	270	350	25160,0	<b>41.1.250.350</b>

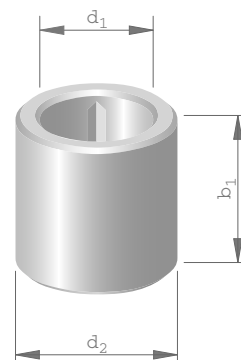

### Schmiernuten

Bis zu einem Innendurchmesser von 12 mm werden die Büchsen ohne Schmiernut, ab 14 mm mit einer axialen Schmiernut geliefert.

### Lubrication grooves

Up to an inner diameter of 12 mm, the bushings are supplied without a lubrication groove; from 14 mm an axial lubrication groove is provided.

### Empfohlene Einbautoleranzen:

Aufnahmebohrung: H7  
Welle: e7

Übrige Toleranzen siehe  
Seiten 8 + 9

### Wir liefern zudem:

- Sonderanfertigungen nach Zeichnung
- andere Werkstoffe für Spezialanwendungen

### Permissible installation tolerances:

Location hole: H7  
Shaft: e7

Other tolerances see pages  
8 + 9

### We also supply:

- Custom-made products according to drawing
- Other metals for special applications

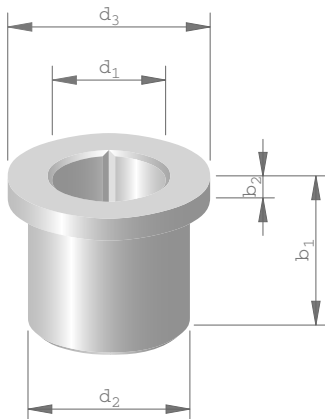

#### Schmiernuten

Bis zu einem Innendurchmesser von 12 mm werden die Büchsen ohne Schmiernut, ab 14 mm mit einer axialen Schmiernut geliefert.

#### Lubrication grooves

Up to an inner diameter of 12 mm, the bushings are supplied without a lubrication groove; from 14 mm an axial lubrication groove is provided.

#### Empfohlene Einbautoleranzen:

Aufnahmebohrung: H7  
Welle: e7

Übrige Toleranzen siehe Seiten 8 + 9

#### Wir liefern zudem:

- Sonderanfertigungen nach Zeichnung
- andere Werkstoffe für Spezialanwendungen

#### Permissible installation tolerances:

Location hole: H7  
Shaft: e7

Other tolerances see pages 8 + 9

#### We also supply:

- Custom-made products according to drawing
- Other metals for special applications

Wellen-Ø [mm] Shaft-Ø [mm]	Abmessungen [mm] Dimensions [mm]			Flansch [mm] Flange [mm]		Gewicht [g] Weight [g]	Artikelnummer Article number
	d <sub>1</sub>	d <sub>2</sub>	b <sub>1</sub>	d <sub>3</sub>	b <sub>2</sub>		
5	5	10	6	12	2	4,0	<b>41.5.005.006</b>
6	6	12	6	14	2	5,0	<b>41.5.006.006</b>
7	7	12	8	16	3	8,0	<b>41.5.007.008</b>
8	8	14	8	18	3	10,0	<b>41.5.008.008</b>
9	9	14	8	18	3	9,0	<b>41.5.009.008</b>
	9	14	10	18	3	11,0	<b>41.5.009.010</b>
10	10	16	8	20	3	12,0	<b>41.5.010.008</b>
	10	16	10	20	3	14,0	<b>41.5.010.010</b>
12	12	18	10	22	3	16,0	<b>41.5.012.010</b>
	12	18	12	22	3	18,0	<b>41.5.012.012</b>
14	14	20	10	25	3	19,0	<b>41.5.014.010</b>
	14	20	12	25	3	22,0	<b>41.5.014.012</b>
15	15	22	12	28	3	28,0	<b>41.5.015.012</b>
	15	22	16	28	3	35,0	<b>41.5.015.016</b>
16	16	22	12	28	4	27,0	<b>41.5.016.012</b>
	16	22	16	28	4	34,0	<b>41.5.016.016</b>
17	17	25	12	32	4	39,0	<b>41.5.017.012</b>
	17	25	16	32	4	48,0	<b>41.5.017.016</b>
18	18	25	12	32	4	36,0	<b>41.5.018.012</b>
	18	25	16	32	4	44,0	<b>41.5.018.016</b>
20	20	28	16	35	4	53,0	<b>41.5.020.016</b>
	20	28	20	35	4	64,0	<b>41.5.020.020</b>
22	22	32	16	40	5	80,0	<b>41.5.022.016</b>
	22	32	20	40	5	92,0	<b>41.5.022.020</b>
25	25	35	16	45	5	94,0	<b>41.5.025.016</b>
	25	35	25	45	5	131,0	<b>41.5.025.025</b>
28	28	40	16	50	5	121,0	<b>41.5.028.016</b>
	28	40	25	50	5	172,0	<b>41.5.028.025</b>
30	30	40	20	50	5	128,0	<b>41.5.030.020</b>
	30	40	30	50	5	172,0	<b>41.5.030.030</b>
35	35	45	20	55	5	141,0	<b>41.5.035.020</b>
	35	45	35	55	5	225,0	<b>41.5.035.035</b>
40	40	50	25	60	6	200,0	<b>41.5.040.025</b>
	40	50	40	60	6	296,0	<b>41.5.040.040</b>
45	45	55	30	65	6	255,0	<b>41.5.045.030</b>
	45	55	45	65	6	358,0	<b>41.5.045.045</b>
50	50	60	30	70	6	276,0	<b>41.5.050.030</b>
	50	60	50	70	6	434,0	<b>41.5.050.050</b>
55	55	70	30	80	8	472,0	<b>41.5.055.030</b>
	55	70	50	80	8	730,0	<b>41.5.055.050</b>
60	60	75	35	85	8	578,0	<b>41.5.060.035</b>
	60	75	60	85	8	930,0	<b>41.5.060.060</b>
65	65	80	35	90	8	620,0	<b>41.5.065.035</b>
	65	80	60	90	8	1000,0	<b>41.5.065.060</b>
70	70	85	35	95	8	660,0	<b>41.5.070.035</b>
	70	85	60	95	8	1060,0	<b>41.5.070.060</b>

## Looser Gleitlager LG 41 – Flanschbüchsen

### Looser bearing LG 41 – Flanged bearing



Wellen-Ø [mm] Shaft-Ø [mm]	Abmessungen [mm] Dimensions [mm]			Flansch [mm] Flange [mm]		Gewicht [g] Weight [g]	Artikelnummer Article number
	d <sub>1</sub>	d <sub>2</sub>	b <sub>1</sub>	d <sub>3</sub>	b <sub>2</sub>		
75	75	90	40	100	8	790,0	<b>41.5.075.040</b>
	75	90	70	100	8	1300,0	<b>41.5.075.070</b>
80	80	95	40	105	8	840,0	<b>41.5.080.040</b>
	80	95	70	105	8	1380,0	<b>41.5.080.070</b>
85	85	100	40	110	8	880,0	<b>41.5.085.040</b>
	85	100	70	110	8	1460,0	<b>41.5.085.070</b>
90	90	110	50	120	8	1510,0	<b>41.5.090.050</b>
	90	110	80	120	8	2350,0	<b>41.5.090.080</b>
95	95	115	50	125	8	1580,0	<b>41.5.095.050</b>
	95	115	80	125	8	2460,0	<b>41.5.095.080</b>
100	100	120	50	130	8	1650,0	<b>41.5.100.050</b>
	100	120	80	130	8	2570,0	<b>41.5.100.080</b>
105	105	125	50	135	8	1730,0	<b>41.5.105.050</b>
	105	125	80	135	8	2690,0	<b>41.5.105.080</b>
110	110	130	50	140	8	1830,0	<b>41.5.110.050</b>
	110	130	80	140	8	2800,0	<b>41.5.110.080</b>
120	120	140	50	150	8	1960,0	<b>41.5.120.050</b>
	120	140	80	150	8	3030,0	<b>41.5.120.080</b>
130	130	150	60	165	10	2650,0	<b>41.5.130.060</b>
	130	150	90	165	10	3770,0	<b>41.5.130.090</b>
140	140	160	60	175	10	2830,0	<b>41.5.140.060</b>
	140	160	90	175	10	4040,0	<b>41.5.140.090</b>
150	150	170	70	185	10	3450,0	<b>41.5.150.070</b>
	150	170	100	185	10	4790,0	<b>41.5.150.100</b>
160	160	180	70	195	10	3680,0	<b>41.5.160.070</b>
	160	180	100	195	10	5090,0	<b>41.5.160.100</b>
170	170	190	70	205	10	3890,0	<b>41.5.170.070</b>
	170	190	100	205	10	5380,0	<b>41.5.170.100</b>
180	180	200	70	215	10	4120,0	<b>41.5.180.070</b>
	180	200	100	215	10	5680,0	<b>41.5.180.100</b>
190	190	210	80	225	10	4870,0	<b>41.5.190.080</b>
	190	210	120	225	10	7080,0	<b>41.5.190.120</b>
200	200	220	80	235	10	5120,0	<b>41.5.200.080</b>
	200	220	120	235	10	7440,0	<b>41.5.200.120</b>
210	210	230	80	245	10	5360,0	<b>41.5.210.080</b>
	210	230	120	245	10	7800,0	<b>41.5.210.120</b>
220	220	240	100	255	10	6870,0	<b>41.5.220.100</b>
	220	240	140	255	10	9420,0	<b>41.5.220.140</b>
230	230	250	100	265	10	7170,0	<b>41.5.230.100</b>
	230	250	140	265	10	9850,0	<b>41.5.230.140</b>
240	240	260	100	275	10	7470,0	<b>41.5.240.100</b>
	240	260	140	275	10	10230,0	<b>41.5.240.140</b>
250	250	270	100	285	10	7760,0	<b>41.5.250.100</b>
	250	270	140	285	10	10640,0	<b>41.5.250.140</b>

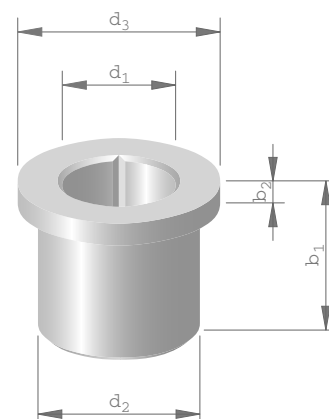

#### Schmiernuten

Bis zu einem Innendurchmesser von 12 mm werden die Büchsen ohne Schmiernut, ab 14 mm mit einer axialen Schmiernut geliefert.

#### Lubrication grooves

Up to an inner diameter of 12 mm, the bushings are supplied without a lubrication groove; from 14 mm an axial lubrication groove is provided.

#### Empfohlene Einbautoleranzen:

Aufnahmebohrung: H7  
Welle: e7

Übrige Toleranzen siehe Seiten 8 + 9

#### Wir liefern zudem:

- Sonderanfertigungen nach Zeichnung
- andere Werkstoffe für Spezialanwendungen

#### Permissible installation tolerances:

Location hole: H7  
Shaft: e7

Other tolerances see pages 8 + 9

#### We also supply:

- Custom-made products according to drawing
- Other metals for special applications

### Zylinderbüchsen LG 41 / Cylindrical bearing LG 41

Vor dem Einbau / Before installation

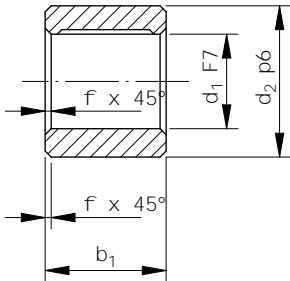

Nach dem Einbau / After installation

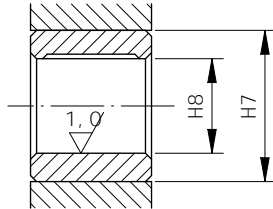

Nach dem Einpressen in eine Gehäusebohrung H7 aus Stahl wird der Innendurchmesser  $d_1$  F7 zu  $d_1$  H8.  
After pressing into a housing bore H7 made of steel, the inner diameter  $d_1$  F7 becomes  $d_1$  H8.

Welle / Shaft

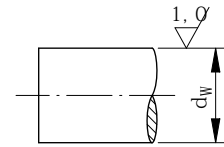

Wellen Härte min. HB 165  
\* Wellentoleranz [ $d_{Wj}$ ] siehe Fussnote  
Shaft hardness: at least 165 HB  
\* Bearing clearance [ $d_{Wj}$ ], see footnote

	Kantenbruch Edge break	Exzentrizität radial und axial Eccentricity radially and axially	Längentoleranz Length tolerance	
			$b_1$ [mm] / von - bis $b_1$ [mm] / from - to	Toleranz [mm] Tolerance [mm]
$d_1$ [mm] / von - bis $d_1$ [mm] / from - to	$f$ [mm] $f$ [mm]	$\mu\text{m}$ $\mu\text{m}$	$b_1$ [mm] / von - bis $b_1$ [mm] / from - to	Toleranz [mm] Tolerance [mm]
- 9	0,3	50	- 10	0/-0,2
> 9 - 18	0,6	50	> 10 - 30	0/-0,3
> 18 - 20	1,0	50	> 30 - 80	0/-0,4
> 20 - 40	1,0	70	> 80 - 350	0/-0,5
> 40 - 50	1,0	100		
> 50 - 75	1,5	100		
> 75 - 120	2,0	100		
> 120 - 160	2,5	100		
> 160	3,0	100		

#### \* Wellentoleranz

Über die Toleranz der Welle wird das Lagerspiel bestimmt. Dieses hängt von mehreren Faktoren ab, wie Belastung, Gleitgeschwindigkeit, Schmiering, Temperatur. Für mit Öl geschmierte und normal beanspruchte Lager empfehlen wir eine Wellentoleranz [ $d_{Wj}$ ] von e7.

#### \* Shaft tolerance

The bearing clearance is determined via the tolerance of the shaft. This depends on several factors, such as load, sliding speed, lubrication and temperature. For normally stressed bearings lubricated with oil, we recommend a shaft tolerance [ $d_{Wj}$ ] of e7.



**Flanschbüchsen LG 41 / Flanged bearing LG 41**

Vor dem Einbau / Before installation

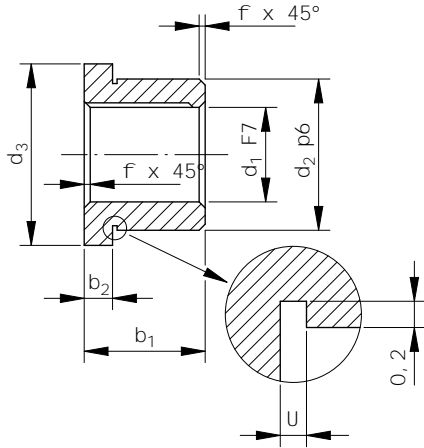

Nach dem Einbau / After installation

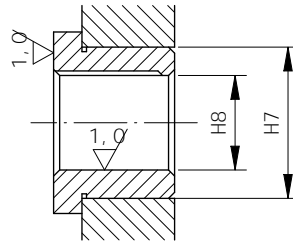

Nach dem Einpressen in eine Gehäusebohrung H7 aus Stahl wird der Innendurchmesser d1 F7 zu d1 H8.  
 After pressing into a housing bore H7 made of steel, the inner diameter d1 F7 becomes d1 H8.

Welle / Shaft

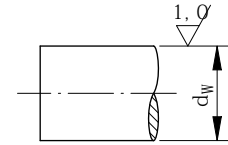

Wellen Härte min. HB 165  
 \* Wellentoleranz [d<sub>W</sub>] siehe Fussnote  
 Shaft hardness: at least 165 HB  
 \* Bearing clearance [d<sub>W</sub>], see footnote

	Kantenbruch Edge break	Freistich Undercut	Exzentrizität radial und axial Eccentricity radially and axially	Längentoleranz Length tolerance	
d <sub>1</sub> [mm] / von - bis d <sub>1</sub> [mm] / from - to	f [mm] f [mm]	U [mm] U [mm]	µm µm	b <sub>1</sub> [mm] / von - bis b <sub>1</sub> [mm] / from - to	Toleranz [mm] Tolerance [mm]
- 9	0,3	1,0	50	- 10	0/-0,2
> 9 - 15	0,6	1,0	50	> 10 - 30	0/-0,3
> 15 - 18	0,6	1,5	50	> 30 - 80	0/-0,4
> 18 - 20	1,0	1,5	50	> 80 - 350	0/-0,5
> 20 - 28	1,0	1,5	70		
> 28 - 40	1,0	2,0	70		
> 40 - 50	1,0	2,0	100		
> 50 - 70	1,5	2,0	100		
> 70 - 75	1,5	3,0	100		
> 75 - 120	2,0	3,0	100		
> 120 - 160	2,5	4,0	100		
> 160	3,0	4,0	100		

**\* Wellentoleranz**

Über die Toleranz der Welle wird das Lagerspiel bestimmt. Dieses hängt von mehreren Faktoren ab, wie Belastung, Gleitgeschwindigkeit, Schmierung, Temperatur. Für mit Öl geschmierte und normal beanspruchte Lager empfehlen wir eine Wellentoleranz [d<sub>W</sub>] von e7.

**\* Shaft tolerance**

The bearing clearance is determined via the tolerance of the shaft. This depends on several factors, such as load, sliding speed, lubrication and temperature. For normally stressed bearings lubricated with oil, we recommend a shaft tolerance [d<sub>W</sub>] of e7.

## Masse der Schmiernute Dimensions of the lubrication groove

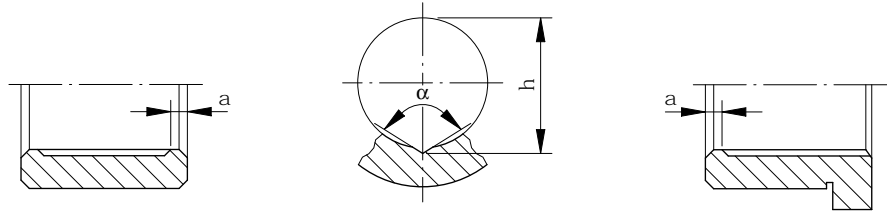

$d_1$ [mm]	$a$ [mm]	$h$ [mm]	$\alpha$
14 - 22	3	$d_1 + 1$	105°
25 - 55	3	$d_1 + 1$	124°
60 - 130	$b_1 \times 0,05$	$d_1 + 1,5$	124°
140 - 190	$b_1 \times 0,05$	$d_1 + 2$	124°
> 190	$b_1 \times 0,05$	$d_1 + 2,5$	124°

## Wellenwerkstoffe Shaft materials

Die Qualität der Welle ist von grosser Bedeutung für die Funktion und die Lebensdauer der Lagerung. Bei mässigen Belastungen soll die Oberflächenhärte der Welle nicht geringer als 165 HB sein. Bei hohen Belastungen ist eine harte Welle mit 250 - 350 HB erforderlich. Wellen mit ungenügender Oberflächenhärte können gehärtet, einsatzgehärtet oder hartverchromt werden (Schichtdicke 50 - 100  $\mu\text{m}$ ). Hartverchromte Wellen haben zudem gute Gleiteigenschaften.

The quality of the shaft is of great importance for the function and service life of the bearing. For moderate loads, the surface hardness of the shaft should not be less than 165 HB. A hard shaft with 250 – 350 HB is required for high loads. Shafts with insufficient surface hardness can be hardened, case hardened or hard chromium plated (layer thickness 50 – 100  $\mu\text{m}$ ). Hard chrome plated shafts also have good sliding properties.

Zu empfehlende Wellenwerkstoffe	
Werkstoff-Nr.	1.0501
"	1.0503
"	1.1191
"	1.6582
"	1.7218
"	1.4057 rostfrei

To recommend shaft-material-numbers	
Nuance n°	1.0501
"	1.0503
"	1.1191
"	1.6582
"	1.7218
"	1.4057 inoxydable

<b>Herstellart: Stangguss oder Schleuderguss</b> <b>Manufacturing method: Continuous casting or centrifugal casting</b>					
<b>Chemische Zusammensetzung</b> <b>Chemical composition</b>		<b>Zulässige Beimengungen</b> <b>Admissible admixtures</b>		<b>Vergleichbare Normen</b> <b>Comparable standards</b>	
Cu	Rest / Rest	Ni *	2,0 %	DIN EN1982	CuSn7Zn4Pb7-C
Sn	6,0 - 8,0 %	Sb	0,3 %	DIN 1705	G-CuSn7ZnPb (Rg7)
Pb	5,0 - 8,0 %	Fe	0,2 %	VSM 10810	G-CuSn7Pb6Zn4 (Rg7)
Zn	2,0 - 5,0 %	P	0,1 %	AFNOR	UE7Z5Pb6
		S	0,1 %	ASTM	Alloy C 93200
		Al	0,01 %	SAE	CA 932 B (660)
		* Ni zählt als Cu			
		* Ni count as Cu			
<b>Mechanische Eigenschaften</b> <b>Mechanical properties</b>			<b>Physikalische Eigenschaften (Richtwerte)</b> <b>Physical properties (Guideline values)</b>		
Streckgrenze $R_{p0,2}$ [N/mm <sup>2</sup> ]				Elastizitätsmodul E [kN/mm <sup>2</sup> ]	
Yield point $R_{p0,2}$ [N/mm <sup>2</sup> ]		≥ 120		Modulus of elasticity E [kN/mm <sup>2</sup> ]	98
Zugfestigkeit $R_m$ [N/mm <sup>2</sup> ]				Wärmeausdehnungskoeffizient [10 <sup>-6</sup> /K]	
Tensile strength $R_m$ [N/mm <sup>2</sup> ]		≥ 260		Coefficient of thermal expansion [10 <sup>-6</sup> /K]	18,5
Bruchdehnung A [%]				Wärmeleitfähigkeit [W/mK]	
Elongation at fracture A [%]		≥ 12		Thermal conductivity [W/mK]	64
Brinellhärte [HB]				Dichte [kg/dm <sup>3</sup> ]	
Brinell hardness [HB]		≥ 70		Specific gravity [kg/dm <sup>3</sup> ]	8,8
<b>Allgemeine Eigenschaften und Verwendungsbeispiele</b> <b>General properties and example uses</b>					
<p>Hervorragende Lagerbronze mit guten Gleiteigenschaften und einer hohen Verschleissfestigkeit, geeignet für Öl- oder Fettschmierung. Einbaufertige Lager für den allgemeinen Maschinenbau, für landwirtschaftliche Maschinen und Baumaschinen, für Textil- und Verpackungsmaschinen, Nebenlager in Werkzeugmaschinen, meerwasserbeständig.</p> <p>Excellent bearing bronze with good sliding properties and high wear resistance, suitable for oil or grease lubrication. Ready-to-install bearings for general mechanical engineering, agricultural and construction machinery, textile and packaging machines, auxiliary bearings in machine tools, seawater-resistant.</p>					

**Walter Looser AG**  
**Bronzen und Gleitlager**  
**Josefstrasse 206**  
**CH-8005 Zürich**

Technische Änderungen vorbehalten, alle Angaben ohne Gewähr.  
Subject to technical modifications; no responsibility is accepted for the accuracy of  
this information.